

Hydraulic grape hoe, working tools Ekonomik

The multipurpose equipment for soil cultivation and weed control among seedlings and trunks in vineyards or orchards, basic tool incl. tine with duck-foot shaped share or chisel. Including hydraulic hoses and quick couplings, hoses length up to 150 cm for side/rear suspension, up to 250 cm for front suspension.

Attention! It is necessary separate free-flow outlet to connect the equipment.

Model	00E400	00E500	00E600	00E700
Knife [cm]	40	50	60	70
Working width [cm]	27	35	43	51
Length [cm]	76	86	96	106
Height [cm]	65			
Width [cm]	31			
Version	right-sided / left-sided			
Hydraulic cylinder for sideshift	single-acting, ø 40 mm			
Oil consumption				
without accessories [l/min]	10			
with PLT [l/min]	30			
Tractor power [kW]	min 10			
Working speed [km/h]	6 - 12			
Weight				
without accessories [kg]	38 – 45			
with PLT [kg]	59 – 65			
with soil removing board [kg]	69 – 76			

* Listed technical data are informative, manufacturer reserves the right to change design and equipment of the machines without prior notice. The machine can be also modified according to the customer's request.

** The working speed may vary depending on the specific working conditions.

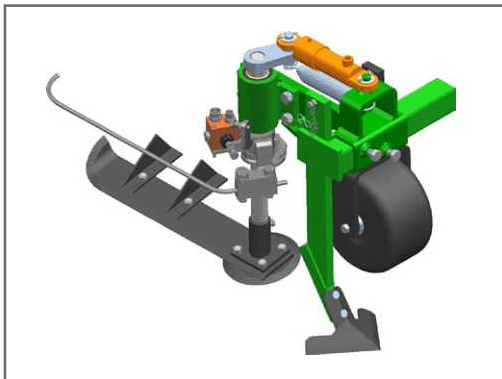

Hydraulic grape hoe, working tools Standard

The multipurpose equipment for soil cultivation and weed control among seedlings and trunks in vineyards or orchards, basic tool incl. tine with duck-foot shaped share or chisel. Including hydraulic hoses and quick couplings, hoses length up to 150 cm for side/rear suspension, up to 250 cm for front suspension.

Attention! It is necessary separate free-flow outlet to connect the equipment.

Model	00S400	00S500	00S600	00S700
Knife [cm]	40	50	60	70
Working width [cm]	27	35	43	51
Length [cm]	77	87	97	107
Height [cm]	65			
Width [cm]	46			
Version	right-sided, left-sided			
Hydraulic cylinder for sideshift	single-acting, ø 40 mm			
Oil consumption				
without accessories [l/min]	10			
with PLT [l/min]	30			
Power demand [kW]	from 10			
Working speed [km/h]	6 - 12			
Weight				
without accessories [kg]	58 – 65			
with PLT [kg]	79 – 85			
with soil removing board [kg]	89 – 96			

* Listed technical data are informative, manufacturer reserves the right to change design and equipment of the machines without prior notice. The machine can be also modified according to the customer's request.

** The working speed may vary depending on the specific working conditions.